

**Quick Hitch Valve**

Page Number  
**80.10.01**

**FEATURES:**

- Economically priced
- Dirt tolerant direct acting valves
- Ultra compact design
- Ductile cast iron body
- Gauge port on reduced pressure
- Reduced pressure to cylinder
- Orifice allows connection to high flow circuits
- Weight 2.1 kg

<b>MODEL</b>	<b>OP137</b>
<b>BODY NO</b>	<b>226387</b>

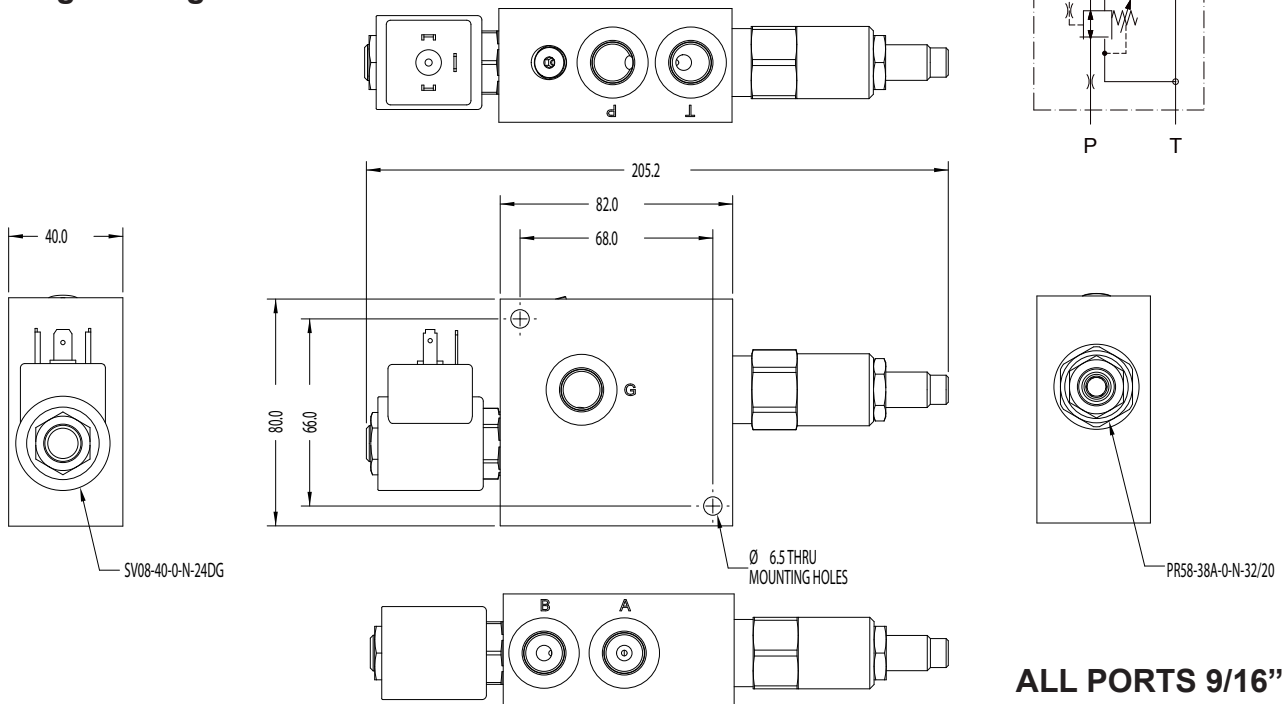

**SPECIFICATIONS**

	<b>OP137 - L</b>	<b>OP137 - H</b>
INLET PRESSURE	350 bar max.	350 bar max.
REDUCED PRESSURE RANGE	Range: 34 - 141 bar	Range: 55 - 220 bar
PRESSURE REDUCER	PR58 - 38A - 0 - P - 20	PR58 - 38A - 0 - P - 32
DIRECTIONAL VALVE	SV08 - 40 - 0 - N - 0	SV08 - 40 - 0 - N - 0
COIL TYPE	6306012, 12 volts DC	6306024, 24 volts DC

Deutsch coil connectors available

Consult Oilpath Hydraulics for selection of alternate model cartridge valves

**ORDERING CODE**

**OP137 - H - 12DC**

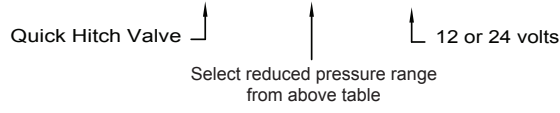

Part number for coil type is for spare parts