

# PIPE LINE NEWS

MARCH 2005

## Model OP10 Valve

### **SUBJECT:**

Change to internal design

### **DUE:**

Commencing August 2005

### **DETAILS:**

The OP10 valve is undergoing an upgrade which will commence in August 2005 with the single spool valve being the first model to receive the changes. The check valve will be repositioned into its own cavity placed at the rear of the valve. The inlet port will be reduced in its length of protrusion from the valve body. The relief will be changed to a new design which is pilot operated and has a new cavity.

### **FEATURES**

- Improved relief valve performance requiring only one spring for full range adjustment
- Ease of service for the check and relief valve
- Improved pressure drop through the valve
- Valves will now have an identification tag on the casting with full part number

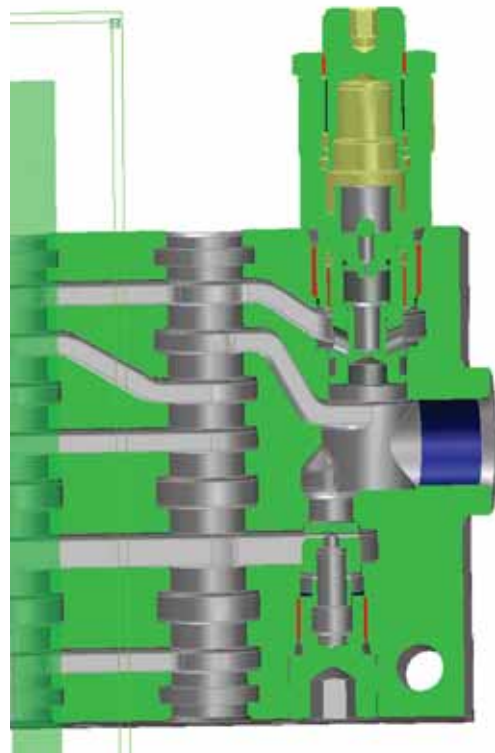

**OILPATH**  
manufacturers of hydraulic control equipment

*For further information contact:*

**OILPATH P/L**  
21 Deloraine Road  
Edwardstown, S.A. 5039  
Australia  
Ph 08 8277 4933  
Fax 08 8277 9126  
sales@oilpath.com.au  
www.oilpath.com.au