

SFP25585

SINGLE VALVE CONTROLLER WITH GAUGE

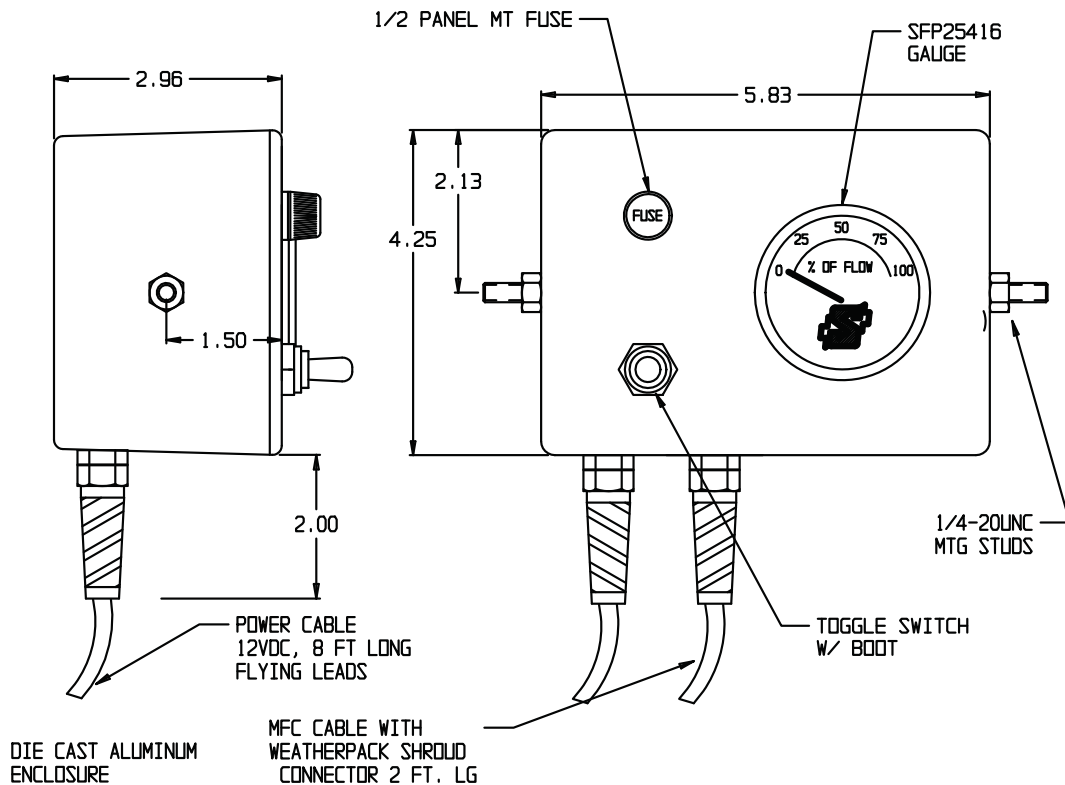

Function:

- **SFP25585** valve control package incorporates a toggle switch (DPDT) and gauge in an enclosure to provide remote control with a visual position indicator for any motorized flow or pressure control equipped with the feedback option.
- The gauge #SFP25416 provides a visual indication (0-100%) of the valve opening so an operator using the toggle switch control can easily return to a previous setting.
- The die cast aluminum housing contains the DPDT toggle switch (P/N 44269), gauge (P/N SFP25416) along with a 3 amp fuse and diode to protect against reverse polarity.

Applications: This system provides a lower cost system for achieving remote speed control of a hydraulic motor. Typical applications are spinner drives on fertilizer, manure, and compost spreaders. Winch drives on fishing vessels and flow controls for concrete pumps.

Specifications:

- Housing 4.75" wide x 3.15" high x 2.38 deep die cast aluminum.
- Operating voltage range 12 to 24 VDC @ 3 amps minimum.
- Power lead 6' long, Motor lead 18" long with Weather Pack connector.
- Panel mount fuse holder, twist to release, 3 amp 3AG fast acting fuse.

How to order:

- Base part number SFP25585. Consult factory for suffix numbers on options.